

Reduce up 75% of purge air loss on your heatless dryer

Return on Investment : Less than 12 months

Typical problems on heatless dryer with time based controller

- A typical heatless dryer will consume average 15% of purge air for regeneration of its absorber to achieve -40°C dew point. If better dew point is required, for example -70°C, more purge air (average 18% ~ 20%) is required.
- A time based heatless dryer are designed based on 100% inlet moisture loading. If the moisture load is reduced in actual operating conditions, the dryer will continue to consume same amount of purge air, based on design conditions.

In actual operating conditions, lower moisture loading can be achieved by :-

- ✓ Reduced air demand
- ✓ Higher operating pressure
- ✓ Lower inlet temperature or
- ✓ Higher dew point required by end user

The solutions – Dew Point Dependent Controller

With dew point dependent controller, a pressure dew point sensor is installed at the outlet of heatless dryer to monitor the dry air's dew point. If the dew point is better than preset limit during adsorption cycle, the adsorption time will extend beyond 5 minutes.

During low load, the load dependent control will

The dew point dependent controller can be easily retrofit into almost any brand of heatless dryer without major modification, and return on investment for the controller is less than 12 months for a dryer's capacity of 1,000m³/hr, and less than 6 months for dryer's capacity bigger than 2,000m³/hr.

Benefits

- Save purge air up to 75%, reduce energy consumption.
- Dew point indicator.
- Dew Point Alarm.
- Time or dew point mode, selectable by end user.

Heatless Dryer
Pressure Release and Desorption Phase

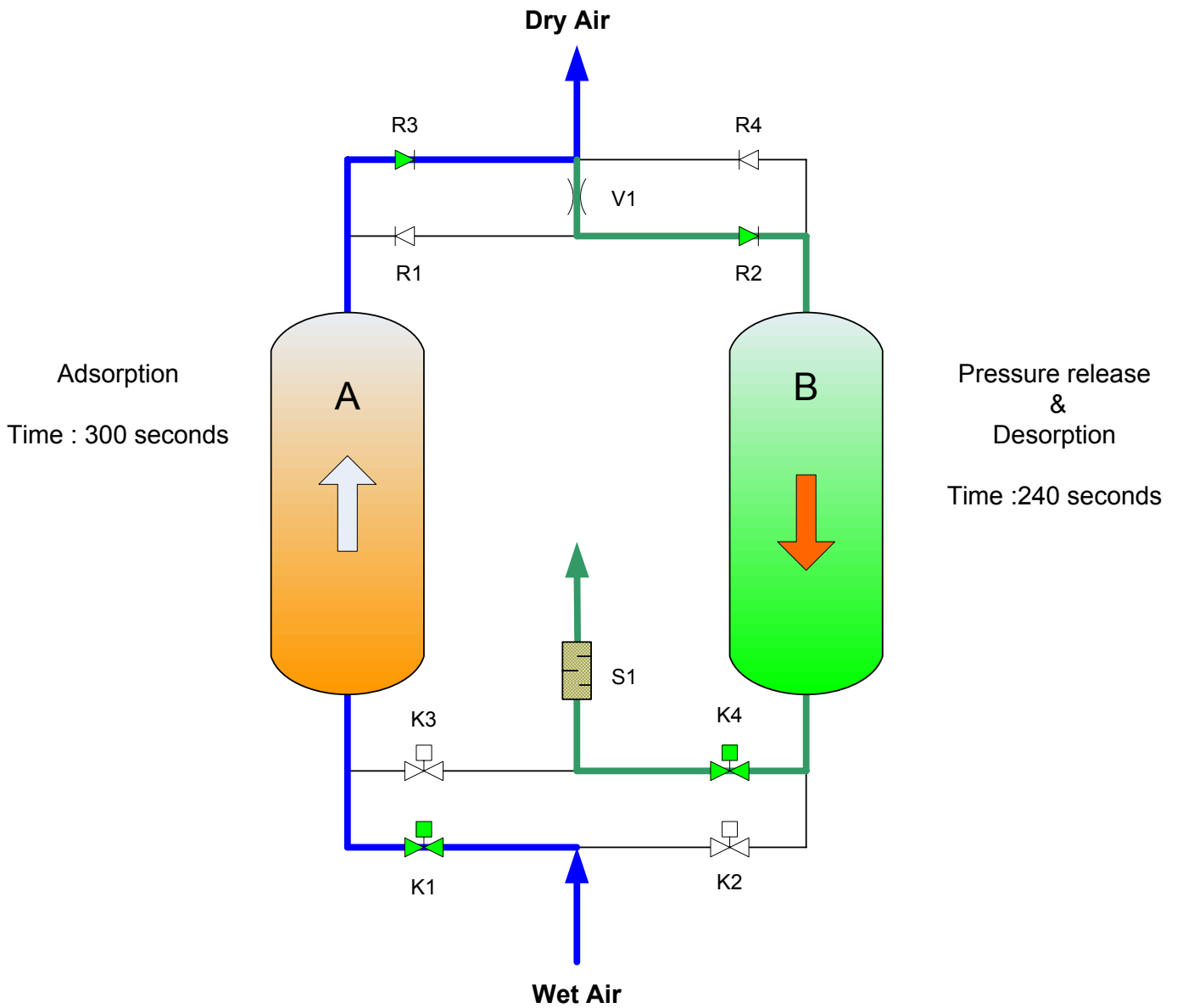

Adsorption Process (B1)

In "time control mode" the duration of the adsorption cycle of an adsorber is fixed to 5 minutes.

Desorption Process (B2)

In "time control mode" the duration of the De-sorption cycle of an adsorber is fixed to 4 minutes.

Heatless Dryer – Time Based Control

Repressurise & Adsorption Phase

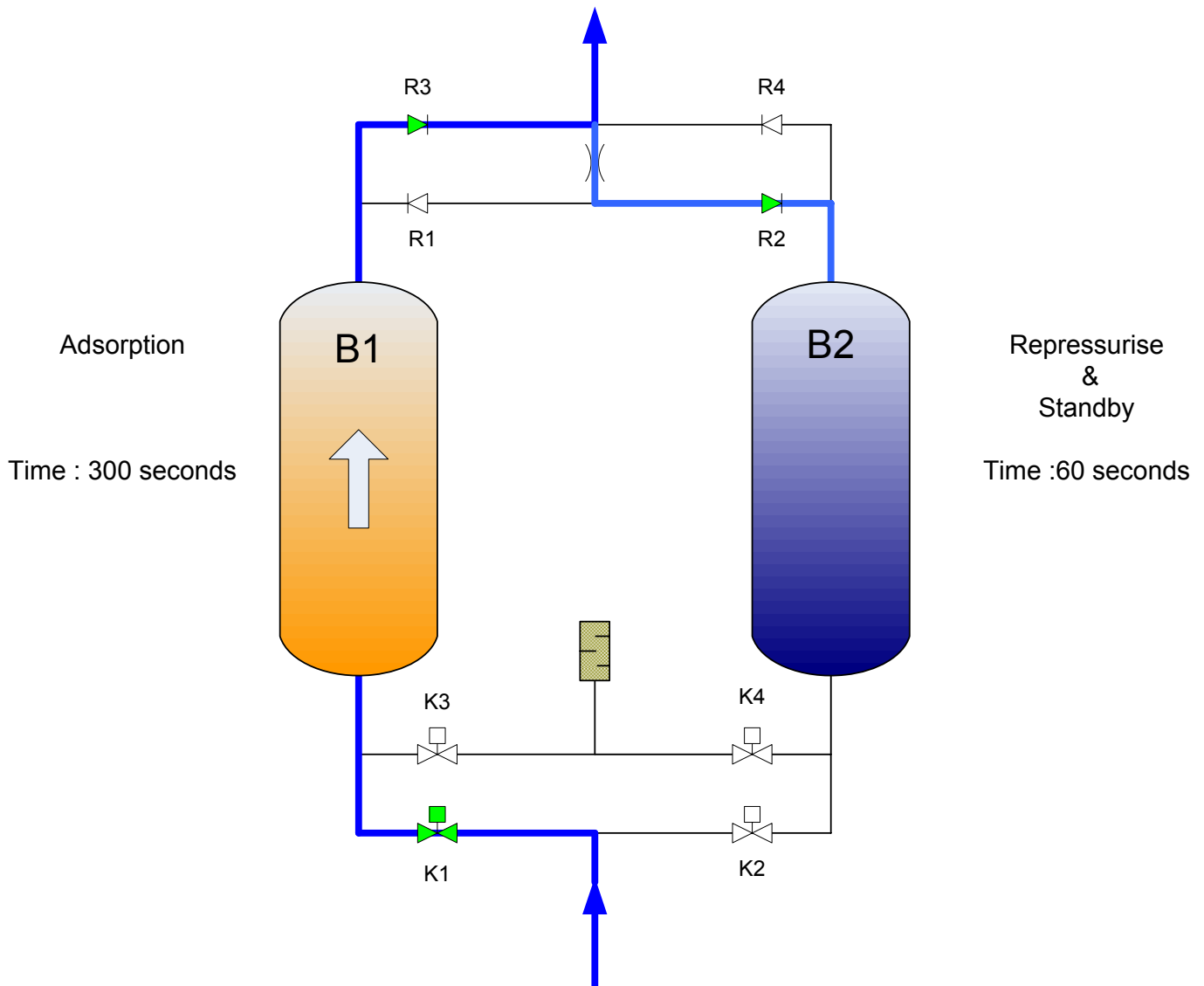

Pressure built up and standby (B2)

In "time control mode" the duration of **pressure built up** and **standby** of an adsorber is fixed to one minute (60 seconds).

Heatless Dryer – Load Dependent Control

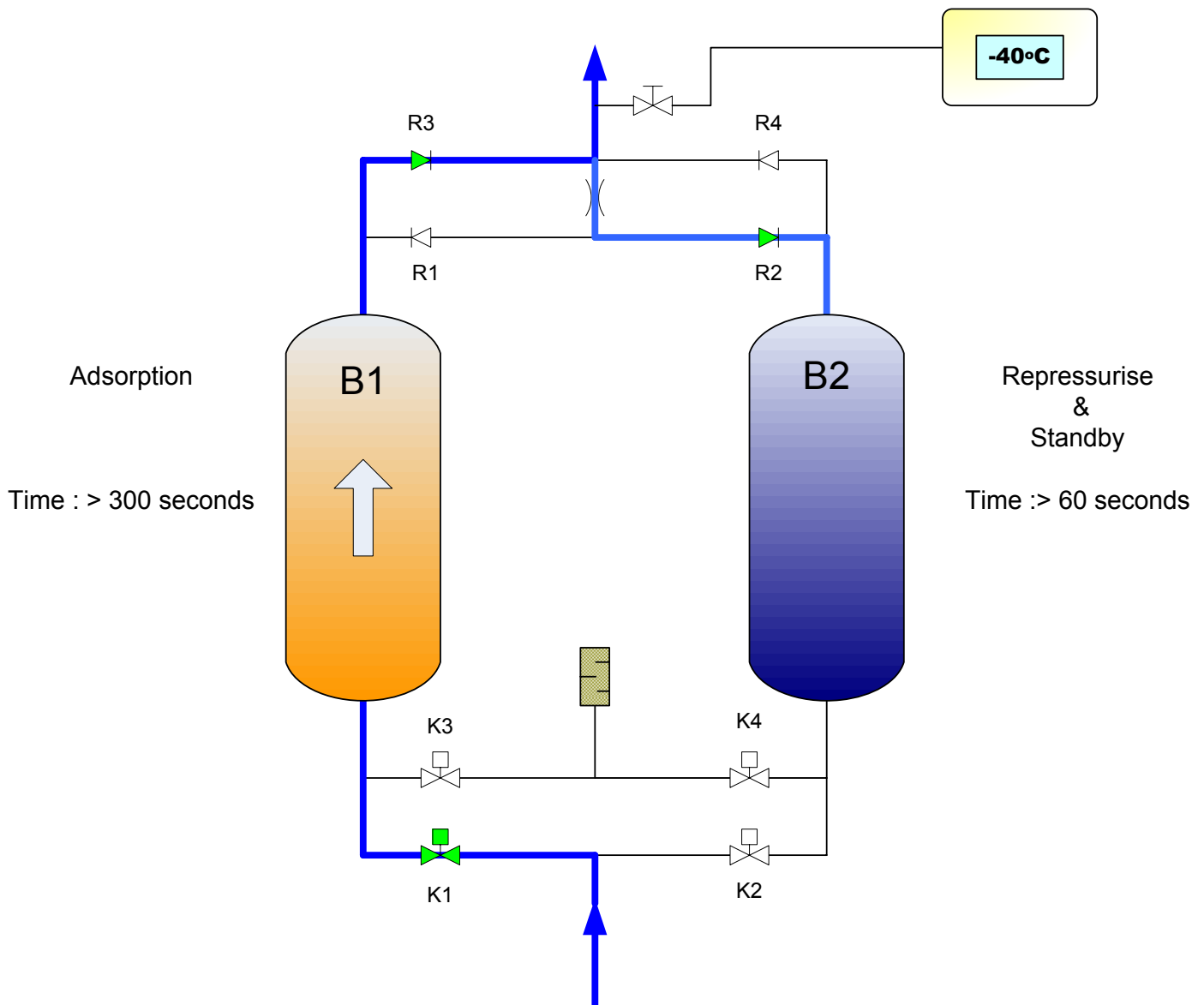

The load dependent control serves the purpose to extend the adsorption cycle of heatless-adsorption dryers in accordance with the actual operating-conditions and to achieve a saving of regeneration-air by an extension of the adsorption-cycle resulting from it, with constant regeneration-duration.

As criterion for the extension of the adsorption-cycle, the pressure dew point is used at the dry-air outlet of the adsorption dryer. The pressure dew point is determined to it with a dew point transmitter.